

CARTRIDGE VALVES

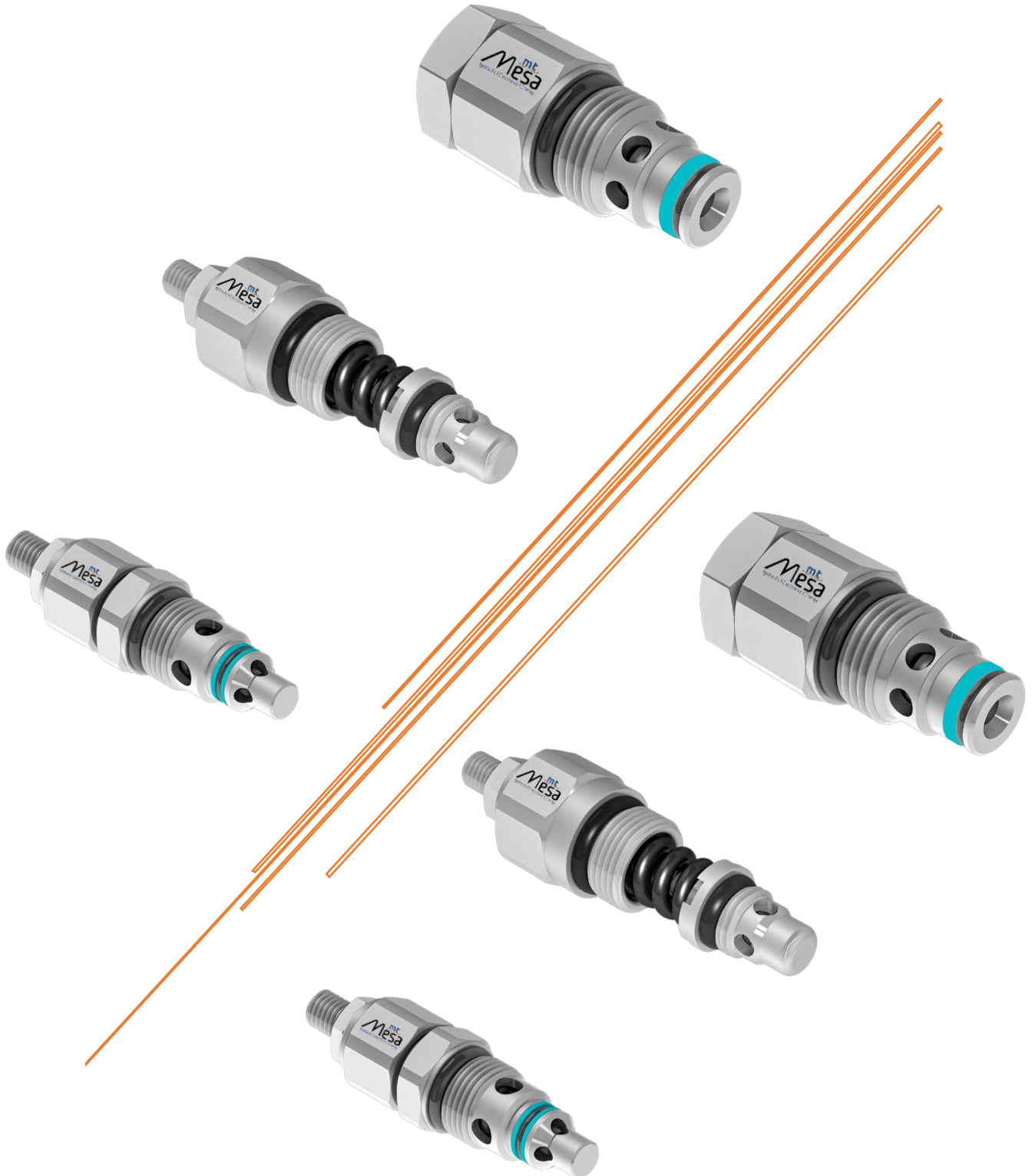

VALVES
REGENERATION OF HYDRAULIC

about US

As a innovative enhancer of Fluid Power Transmission Industry that MT MESA is became a global leader with its premium quality products in Global Hydraulics markets.

From the beginning till today, We provide R&D to contribute the sustainable and smart product solutions for components, systems of drive and automation technology in MT MESA.

MT MESA is one of the major suppliers among the Fluid Power Engineering Industry Professional manufacturers to the entire mechanical-engineering industry and many other industries, such as electrical engineering, construction and agricultural machinery, conveyor systems, chemical industry, food and packaging machinery, woodworking, machine tools, shipbuilding, the metal industry, mining and environmental technology.

ADVANCED MANUFACTURING;

Today, companies divide their operations across the world, from the design of the product and manufacturing of components to assembly and marketing, creating international production chains.

Both MESA MAKINA A.S. and MT MESA has operating from the engineering design, casting and machining till to assembling lines and shipment operations in same integrated facility. This business awareness and production ability enables us the strongest position in our business scope by means of our R&D Center guided business operations inhouse. Our global – nationwide shipment operations are carried out under the same roof. By this way our patented products are delivered in time.

MT MESA has also ISO 9001 and IATF 16949, ISO 14001, ISO 18001, ISO 27001 Certificates since 2000. The EFQM Excellence Model is the only company that has a 4 Star Quality Competency Certificate and has received an award.

A GAME CHANGER;

MT MESA - MESA MAKINA A.S. is the indivisible part of International Fluid Power Society as a member of Akışkan Gücü Derneği (AKDER) – Accredited to CETOP (Comité Européen des Transmissions Oléohydrauliques et Pneumatiques ,European Fluid Power Committee).

As a part of MESA MAKINA A.S. , MT MESA has international business interactions and professional collaborations with leading USA & EU business partners in Hydraulic Industry.

MT MESA offers you a wide range of filtration solutions to meet with your hydraulic system requirements perfectly. We ultimately care about all customer feedback to provide smart & quick solutions for the hydraulic sector professionals, students and individuals.



technical INFORMATION

Please read these instructions carefully before installation. All operations must be carried out by specialized and competent personnel.

The user must periodically check the condition and correct functioning of the valves, the corrosion and the condition of the hydraulic installation.

Always respect the technical prescriptions of the valve.

OIL

Use only mineral oil (HL, HLP) according to DIN 51524. The use of other fluids may cause bad working of the valve.

OPERATING TEMPERATURES

Environment temperature: -25°C to +60°C

Oil temperature (with NBR seals): from -25°C to +75°C

VISCOSITY

The viscosity of the oil should be in the range of 15 mm²/s to 250mm²/s.

Recommended viscosity ISO VG 46 (for cartridge valves ISO VG 32).

CONTAMINATION AND FILTRATION

Excessive fluid contamination is the main cause of bad-working in hydraulic installations.

Max. contamination with filter ISO 4406:1999 - class 19/17/14

The use of filters is necessary to protect the system from bad-working, in order to avoid serious consequences for the hydraulic installation and people.

we recommend a filtration of 15 microns for its valves

POWER SUPPLY

The solenoid valve coils must be supplied with voltages between +/- 10% of the nominal voltage at a maximum environment temperature of 60°C.

SEALING

O-rings mounted on the valves are in NBR

The anti-extrusion rings used to protect the O-rings are made of PTFE or NBR.

TESTING CONDITIONS

All the tests shown in the catalogue were carried out with mineral oil ISO VG 46 at a temperature of 40°C and an absolute filtration degree of 15 microns.

MTPTCV*S CHECK VALVES POPPET TYPE SINGLE ACTING PILOT CHECK VALVES **SAE 8/2**

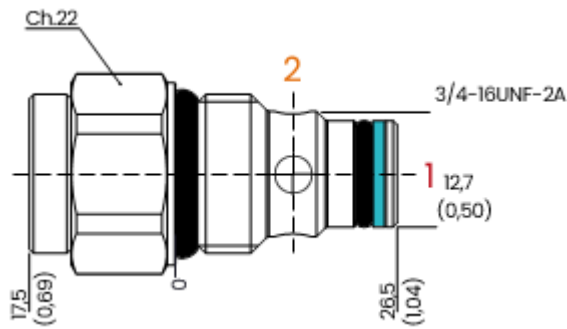

HYDRAULIC CIRCUIT



PERFORMANCES

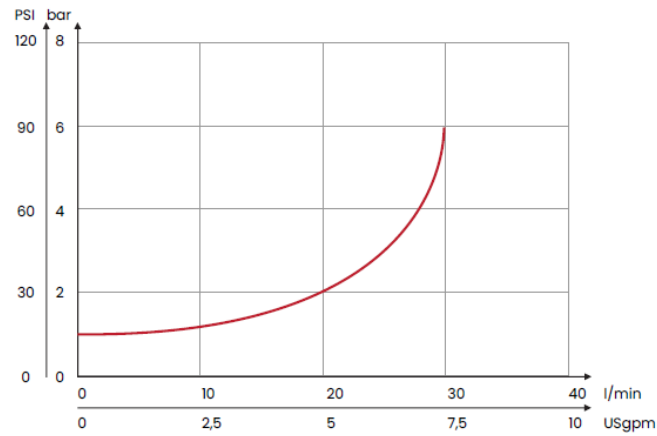

ORDERING CODE

ORDERING CODE	CAVITY	SPRING	MAX FLOW l/min [USgpm]	MAX PRESSURE bar [PSI]	TIGHTENING TORQUE Nm [lbt ft]	WEIGHT kg [lbt]
MTPTCV105S	SAE8/2	0,5 bar [7,3 PSI]	30 [1,18]	350 [5075]	30 [22]	0,06 [0,13]
MTPTCV130S		3 bar [43,5 PSI]				
MTPTCV145S		4,5 bar [65,5 PSI]				

Mineral oil: DIN 51524 ISO 6743/4 | Oil viscosity: 15 to 250 cSt 15-250 mm²/s | Oil temperature: -4°F + 176°F -20°C +80°C | Ambient temperature: -4°F + 122°F -20°C +50°C | Max contamination index with filter: 5 to 250 cSt 15-250 mm²/s | It is necessary a filter use to protect the valve (advised filtration 15 µm) | Max leakage: 0,25 cm³/min - 5 drops/min

MT20EV*C RELIEF VALVES 20 L **SAE 8/2**

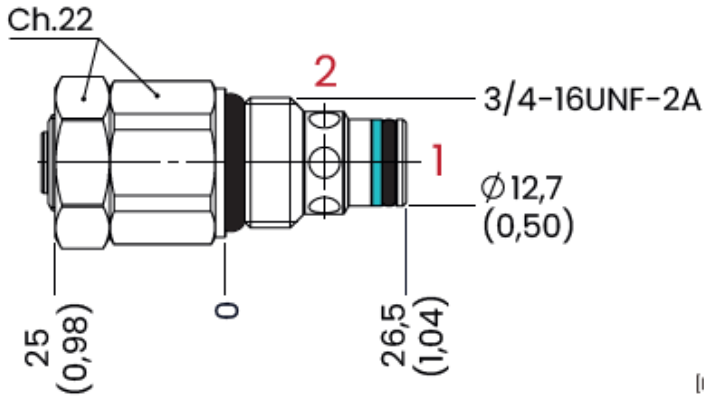

HYDRAULIC CIRCUIT

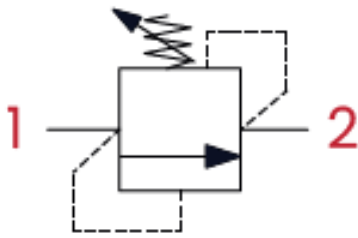

PERFORMANCES

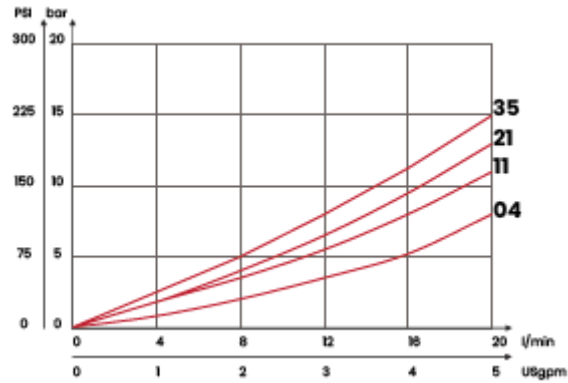

ORDERING CODE

ORDERING CODE	CAVITY	RAGE SPRING	INCREASE TO TURN	MAX FLOW l/min [USgpm]	MAX PRESSURE bar [PSI]	TIGHTENING TORQUE Nm [lbt ft]	WEIGHT kg [lbt]
MT20EV04C	SAE8/2	10/40 bar [145/580 PSI]	20 bar/ al giro [290 PSI/turn]	20 [5,3]	350 [5075]	30 [22]	0,11 [0,24]
MT20EV11C		20/110 bar [290/1959 PSI]	40 bar/ al giro [580 PSI/turn]				
MT20EV21C		30/210 bar [435/3045 PSI]	70 bar/ al giro [1015 PSI/turn]				
MT20EV35C		40/350 bar [580/5075 PSI]	130 bar/ al giro [1885 PSI/turn]				

Mineral oil: DIN 51524 ISO 6743/4 | Oil viscosity: 15 to 250 cSt 15-250 mm²/s | Oil temperature: -4°F + 176°F -20°C +80°C | Ambient temperature: -4°F + 122°F -20°C +50°C | Max contamination index with filter: 5 to 250 cSt 15-250 mm²/s | It is necessary a filter use to protect the valve (advised filtration 15 µm) | Max leakage: 0,25 cm³/min - 5 drops/min at 80% of the calibration pressure

MT40EV*C RELIEF VALVES 40 L **M20 x 1,5**

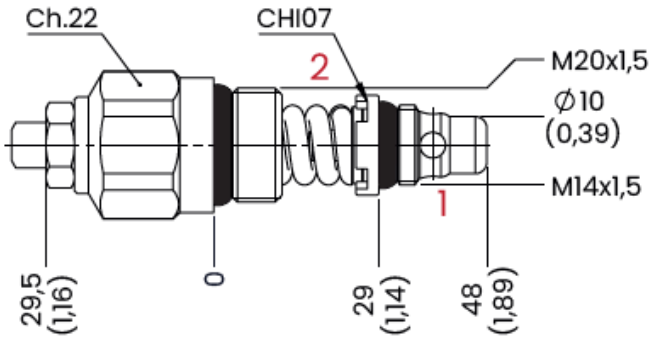

mm
[Inches]

HYDRAULIC CIRCUIT

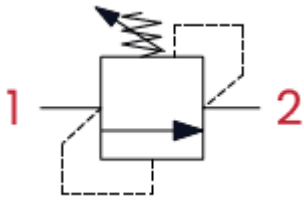

PERFORMANCES

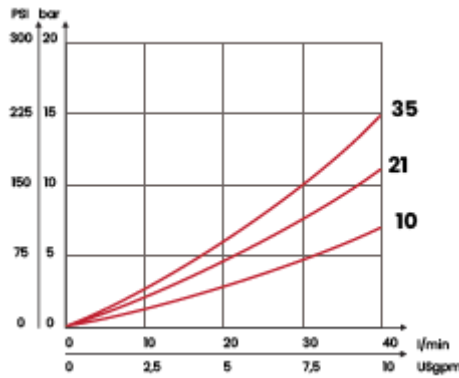

OPTIONAL TOOL

TYPE
CHI07

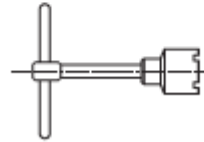

ORDERING CODE

ORDERING CODE	CAVITY	RAGE SPRING	INCREASE TO TURN	MAX FLOW l/min [USgpm]	MAX PRESSURE bar [PSI]	M14X1,5 TIGHTENING TORQUE Nm [lbt ft]	M20X1,5 TIGHTENING TORQUE Nm [lbt ft]	WEIGHT kg [lbt]
MT40EV10C	M20 x 1,5	10/100 bar [145/1450 PSI]	12 bar/al giro [174 PSI/turn]	40 [10,6]	350 [5075]	10 [7]	40 [30]	0,13 [0,29]
MT40EV21C		20/210 bar [290/2045 PSI]	33 bar/al giro [479 PSI/turn]					
MT40EV35C		70/350 bar [1015/5075 PSI]	70 bar/al giro [1015 PSI/turn]					

Available with handknob

Mineral oil: DIN 51524 ISO 6743/4 | Oil viscosity: 15 to 250 cSt 15-250 mm²/s | Oil temperature: -4°F + 176°F -20°C +80°C | Ambient temperature: -4°F + 122°F -20°C +50°C | Max contamination index with filter: 5 to 250 cSt 15-250 mm²/s | It is necessary a filter use to protect the valve (advised filtration 15 µm) | Max leakage: 0,25 cm³/min - 5 drops/min at 80% of the calibration pressure

MT42EV*C RELIEF VALVES 40 L SAE 10/2

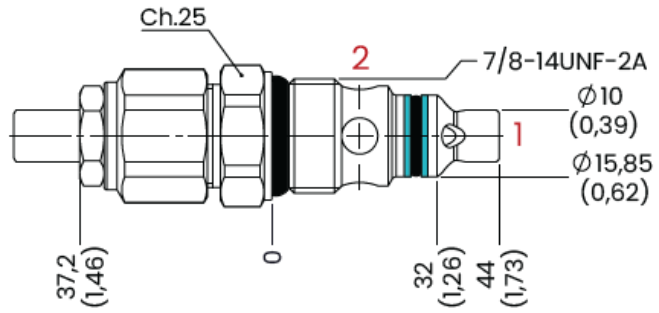

mm
[Inches]

HYDRAULIC CIRCUIT

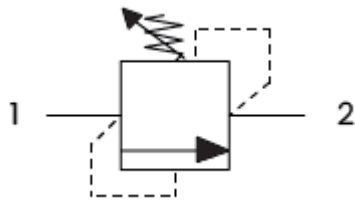

PERFORMANCES

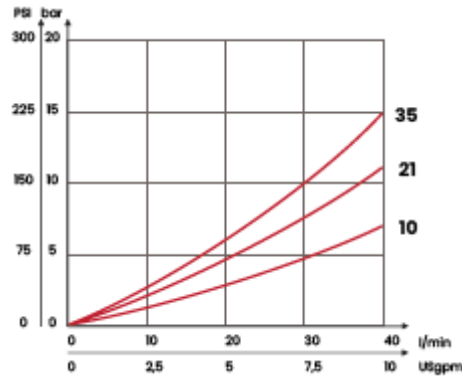

ORDERING CODE

ORDERING CODE	CAVITY	RAGE SPRING	INCREASE TO TURN	MAX FLOW l/min [USgpm]	MAX PRESSURE bar PSI	TIGHTENING TORQUE Nm [lbt ft]	WEIGHT kg [lbt]
MT42EV10C	SAE 10/2 [7/8-14 UNF]	10/100 bar [145/1450 PSI]	12 bar/al giro [174 PSI/turn]	40 [10,6]	350 [5075]	40 [30]	0,18 [0,37]
MT42EV21C		20/210 bar [290/2045 PSI]	33 bar/al giro [479 PSI/turn]				
MT42EV35C		70/350 bar [1015/5075 PSI]	70 bar/al giro [1015 PSI/turn]				

Available with handknob

Mineral oil: DIN 51524 ISO 6743/4 | Oil viscosity: 15 to 250 cSt 15-250 mm²/s | Oil temperature: -4°F + 176°F -20°C +80°C | Ambient temperature: -4°F + 122°F -20°C +50°C | Max contamination index with filter: 5 to 250 cSt 15-250 mm²/s | It is necessary a filter use to protect the valve (advised filtration 15 µm) | Max leakage: 0,25 cm³/min - 5 drops/min at 80% of the calibration pressure